

SHOWCASE CATALOG

Merchandising Displays

Showcases

Counter Units

Shelving Systems

Table of Contents

| SECTIONS | PAGE |
|--|-------------|
| Company profile / Products & Services | 5 |
| Specifications: Showcases | 6 |
| Modular Series: Refrigerated Pastry Showcases..... | 8 |
| Modular Series: Non-Refrigerated Bakery Showcases..... | 9 |
| Modular Series: Refrigerated Delicatessen / Savory Showcases..... | 10 |
| Modular Series: Refrigerated Chocolate Showcases..... | 11 |
| Modular Series: Hot Food Showcases..... | 12 |
| Modular Series: Sandwich Preparation Showcases..... | 13 |
| High Volume Series: Refrigerated Pastry Showcases..... | 14 |
| High Volume Series: Non-Refrigerated Showcases..... | 15 |
| High Volume Series: Hybrid Showcases..... | 16 |
| “Grab n Go” Series: Refrigerated Upright Showcases..... | 17 |
| “Grab n Go” Series: Refrigerated / Non Refrigerated Combo Showcases..... | 18 |
| “Grab n Go” Series: Refrigerated Lowboy Showcase..... | 19 |
| Café Series: Refrigerated Showcases..... | 20 |
| Café Series: Non-Refrigerated Showcases..... | 21 |
| Café Series: Hot Food Showcases..... | 22 |
| Café Series: Sandwich Preparation Showcases..... | 23 |
| Custom Front Service Counters..... | 24 |
| Options and Accessories..... | 25 |
| Specifications: Wall Mounted / Backwall Display Systems | 26 |
| Projects/Installations | 28 |

Company Profile

Vega Mfg Ltd. has been a leading custom manufacturer of European designed showcases and merchandising displays for the food industry since 1991. We specialize in the design and production of refrigerated and non-refrigerated display showcases for a variety of food products, such as baked goods, chocolates, confections, delicatessen products, sandwiches, salads, etc. Each one is tailor made to each client's particular needs and styles.

Vega's philosophy is the embodiment of Design, Functionality, and Craftsmanship.

Design

European design and innovation are brought to North America. The streamlined design and visual appeal give our displays a distinctive style. Vega provides its clients with an ideal merchandising tool, emphasizing the product being displayed and not the display itself. All of our products are made to meet the clients' particular needs, from required lengths to the preferred finishes. This allows for seamless integration into any location.

Functionality

Vega uses state of the art components such as our showcases' refrigeration and airflow systems, to keep products fresh. Well highlighted and appealing products in coordination with easy staff-patron interaction help to increase sales. Energy efficient components and reduced product spoilage help save the client money. Increasing sales and saving money – that's what a Vega display system can do.

Craftsmanship

President Walter Kollenberg keeps his hands on each display project from start to finish. His team of European trained craftsmen makes each display with exacting specifications to meet all of the clients' needs. Vega displays house solid-state components. All of our displays are backed by an exclusive warranty.

The Final Word

Vega Mfg Ltd. produces the finest quality displays and accessories to meet every need and style of its clientele.

Vega is Success in Design, Functionality, and Craftsmanship.

Products & Services Information

Customized Designs

Vega provides the highest quality products to suit your particular needs. Specializing in custom display showcases, we also provide a full compliment of corner units, counters and shelving. With custom finishes, the displays are made to match any location's interior design.

Quality Assurance

Every one of our display units carries the Vega seal of quality and is backed by our exclusive one year limited warranty program. All of our display cases are NSF and CSA/US approved and manufactured with energy efficient solid state components. Vega prides itself on the safe and reduced usage of CFC's (chlorofluorocarbon refrigerants) when manufacturing, installing, operating and maintaining our displays. Finally, customer service and technical support for our clients are of the utmost importance. With our convenient toll free number 1-800-224-8342, we are just a phone call away to help you maximize the benefits and uses of our displays.



Showcases

Vega products are designed specifically for each establishment. We have showcases designed for baked goods, pastries, delicatessen products, chocolates, sandwiches, etc. We have the products to meet the needs of any market segment in the food industry.

The standard features of tilt down curved front glass, warm tone lighting, light colored extrusions and precise shelf placement combine to best highlight the products within. By utilizing our specially designed refrigeration and airflow systems, an ideal environment is maintained to keep products fresh and appealing.

Our standard modular unit lengths are 962 mm (3'-2") and 1412 mm (4'-7 1/2"). These units can be combined to make almost any length, with custom corner cases and counter units to ensure the perfect fit. With an almost limitless choice of finishes, each showcase will integrate seamlessly into any location.

Modular Series Showcases:

The distinct features of the modular series are the large visual display area and the convenient customer side purse shelf. The internal display configuration is made specifically for each type of product. The various models in this series provide the flexibility to suit many different applications.

High Volume Series Showcases:

Designed primarily for bakery and Coffee Shop / Cafe products, this series of showcases maximizes the overall capacity for products displayed.

"Grab n Go" Series Showcases:

Designed with the "customer on the go" in mind. The convenience of self serve and the consistent display for a variety of prepared goods. Display more product and serve more people.

Café Series Showcases:

Made specifically for cafeteria style service, these showcases feature a tray shelf (replacing the purse shelf in the Modular Series). This series of showcases provides consistent display for a full variety of prepared foods.

Custom Front Service Counter:

The counters are designed to integrate into any type of showcase and provide space for full customer service.

Options and Accessories

Vega compliments its showcases with a wide variety of optional extras to help customize and realize all display possibilities.

Standard Showcase Lengths (Other Lengths Available)

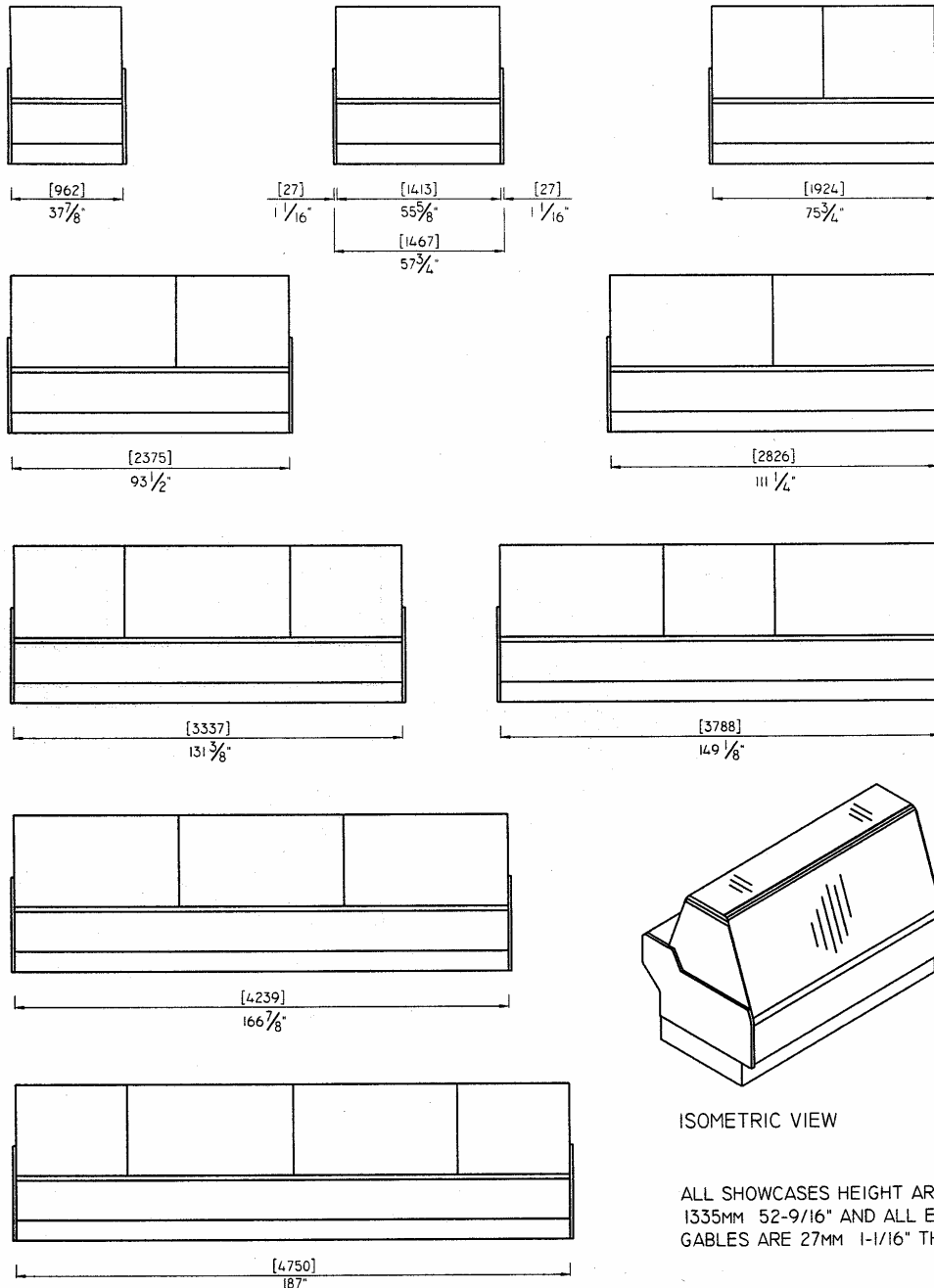

Modular Series: Refrigerated Pastry Showcases

Vega's Pastry Showcases utilize the specially made refrigeration and airflow systems to ensure the proper environment for cakes and pastries. The combination of streamlined design and leading edge components enhances and maintains product appearance and freshness.

Features and benefits:

- **Tilt down curved front glass**
 - streamlined design & aesthetically pleasing
 - ease of cleaning
- **Warm tone lighting above each display level**
 - enhances product display & visibility
- **Electronic ballasts**
 - energy efficient & long lasting
- **Two intermediate glass shelves**
 - increased capacity & visual appeal
- **Intermediate top-glass barrier**
 - reduces condensation on top of showcase
- **Pull-out sliding drawer(s)**
 - ergonomic & convenient access to product
- **Clear acrylic sliding service doors**
 - convenient access & clear work-side view
- **Plastic laminate finished work shelf**
 - useful work space
- **Glass end panels (Mirror finish available)**
 - clear visibility
 - removable for ease of cleaning
- **Anodized finished aluminum superstructure**
 - eye pleasing & durable finish
- **Plastic laminate finished exterior**
 - matches décor
- **Melamine finished open storage shelf**
 - convenient staff storage space
- **Powder coated painted steel base frame**
 - strong & durable
- **Insulated stainless steel refrigeration pan**
 - sanitary (meets health standards)
- **Front glass defogger**
 - minimizes front glass condensation
- **Refrigeration system**
 - consistent cooling
- **Extra large refrigeration coil**
 - high humidity
- **Adjustable air circulating system**
 - maintains consistent temperature
- **Computerized temperature controller with automatic defrost**
 - active sensor reading & energy efficient
- **Optional: purse shelf**
 - customer convenience & visual accent

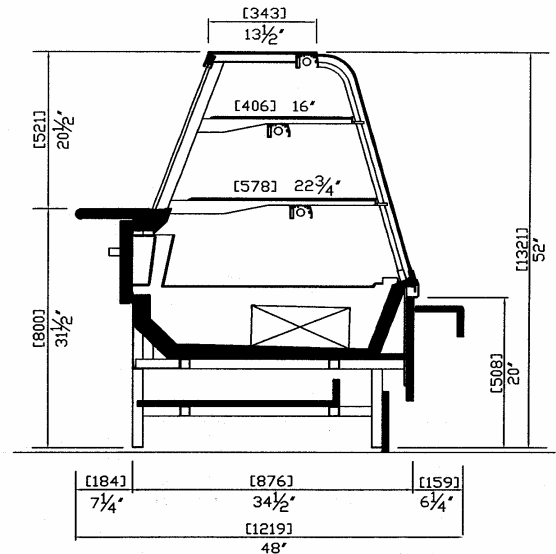

Electrical & Refrigeration Requirements:

- 1 circuit – 115 volts – 15 amps.

Refrigeration Requirements:

- optional water or air cooled condensing unit
- R-22 (others available) medium temperature
- separate electrical line as required for condensing unit

Mechanical Requirement:

- 3" hub drain – not required if Self-Contained

Temperature:

- Internal temperature of the showcase operates at 39°F (4°C) and 70% relative humidity, at an ambient temperature of 77°F (25°C) and 50% humidity.

Specifications subject to change without notice.

Modular Series: Non-Refrigerated Bakery Showcases

Vega's Modular Series Non-Refrigerated Pastry Showcases are designed to highlight and enhance product presentation. The combination of tilt-down curved front glass, warm tone lighting and light colored extrusions ensure the baked goods are the center of attention.

Features and benefits:

- **Tilt down curved front glass**
 - streamlined design & aesthetically pleasing
 - ease of cleaning
- **Warm tone lighting above each display level**
 - enhances product display & visibility
- **Electronic ballasts**
 - energy efficient & long lasting
- **Two intermediate glass shelves**
 - increased capacity & visual appeal
- **Angle base display (ready for cake trays)**
 - clear product visibility
- **Clear acrylic sliding service doors**
 - convenient access & clear work-side view
- **Plastic laminate finished work shelf**
 - useful work space
- **Glass end panels (Mirror finish available)**
 - clear visibility
 - removable for ease of cleaning
- **Anodized finished aluminum superstructure**
 - eye pleasing & durable finish
- **Plastic laminate finished exterior**
 - matches décor
- **Melamine finished open storage shelf**
 - convenient staff storage space
- **Powder coated painted steel base frame**
 - strong & durable
- **Optional: purse shelf**
 - customer convenience & visual accent

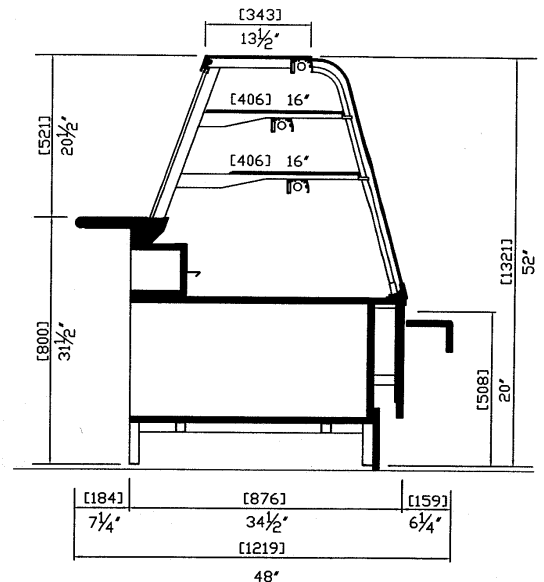

- **Electrical Requirements:**
 - 1 circuit – 115 volts – 15 amps.

Specifications subject to change without notice.

Modular Series: Refrigerated Delicatessen/Savory Showcases

Vega's Modular Series Refrigerated Delicatessen Showcases utilize the specially made refrigeration and airflow systems to ensure the proper environment for meats and cheeses. The combination of streamlined design and leading edge components enhances and maintains product appearance and freshness.

Features and benefits:

- **Tilt down curved front glass**
 - streamlined design & aesthetically pleasing
 - ease of cleaning
- **Warm tone lighting above each display level**
 - enhances product display & visibility
- **Electronic ballasts**
 - energy efficient & long lasting
- **One intermediate glass shelf**
 - increased capacity & visual appeal
- **Intermediate top-glass barrier**
 - reduces condensation on top of showcase
- **Two step stainless steel display platform**
 - increased capacity & visual
- **Clear acrylic sliding service doors**
 - convenient access & clear work-side view
- **Plastic laminate finished work shelf**
 - useful work space
- **Glass end panels (Mirror finish available)**
 - clear visibility
 - removable for ease of cleaning
- **Anodized finished aluminum superstructure**
 - eye pleasing & durable finish
- **Plastic laminate finished exterior**
 - matches décor
- **Melamine finished open storage shelf**
 - convenient staff storage space
- **Powder coated painted steel base frame**
 - strong & durable
- **Insulated stainless steel refrigeration pan**
 - sanitary (meets health standards)
- **Front glass defogger**
 - minimizes front glass condensation
- **Refrigeration system**
 - consistent cooling
- **Extra large refrigeration coil**
 - high humidity
- **Adjustable air circulating system**
 - maintains consistent temperature
- **Computerized temperature controller with automatic defrost**
 - active sensor reading & energy efficient
- **Optional: purse shelf**
 - customer convenience & visual accent

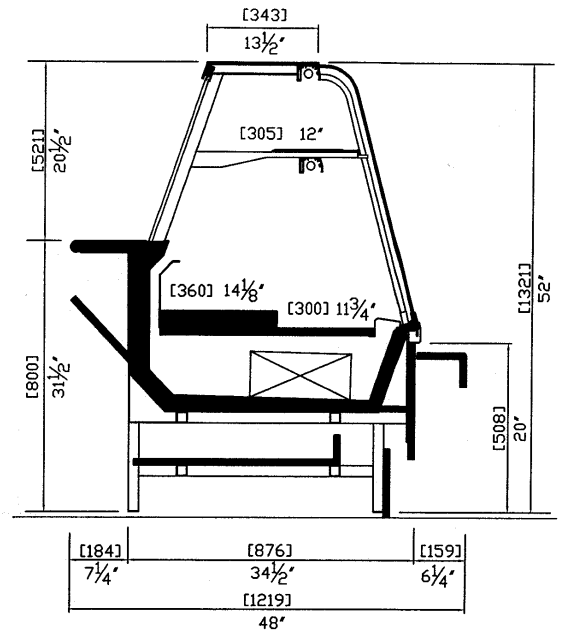

Electrical Requirements:

- 1 circuit – 115 volts – 15 amps.

Refrigeration Requirements:

- optional water or air cooled condensing unit
- R-22 medium temperature
- separate electrical line as required for condensing unit

Mechanical Requirement:

- 3" hub drain – not required if Self-Contained

Temperature:

- Internal temperature of the showcase operates at 39°F (4°C) and 70% relative humidity, at an ambient temperature of 77°F (25°C) and 50% humidity.

Specifications subject to change without notice.

Modular Series: Refrigerated Chocolate Showcases

Vega's Modular Series Refrigerated Chocolate Showcases utilize the low humidity refrigeration and airflow systems to ensure the proper environment for chocolates. The combination of curved front glass, warm tone lighting and light colored display ensures the chocolates are the center of attention.

Features and benefits:

- **Tilt down curved front glass**
 - streamlined design & aesthetically pleasing
 - ease of cleaning
- **Warm tone lighting above each display level**
 - enhances product display & visibility
- **Electronic ballasts**
 - energy efficient & long lasting
- **One intermediate glass shelf**
 - increased capacity & visual appeal
- **Three step anodized aluminum display platform**
 - increased capacity & visual
- **Clear acrylic sliding service doors**
 - convenient access & clear work-side view
- **Plastic laminate finished work shelf**
 - useful work space
- **Glass end panels (Mirror finish available)**
 - clear visibility
 - removable for ease of cleaning
- **Anodized finished aluminum superstructure**
 - eye pleasing & durable finish
- **Plastic laminate finished exterior**
 - matches décor
- **Melamine finished open storage shelf**
 - convenient staff storage space
- **Powder coated painted steel base frame**
 - strong & durable
- **Small refrigeration coil**
 - low humidity
- **Adjustable air circulating system**
 - maintains consistent temperature
- **Computerized temperature controller with automatic defrost**
 - active sensor reading & energy efficient
- **Low humidity refrigeration system**
 - maintains proper humidity level
- **Optional: purse shelf**
 - customer convenience & visual accent

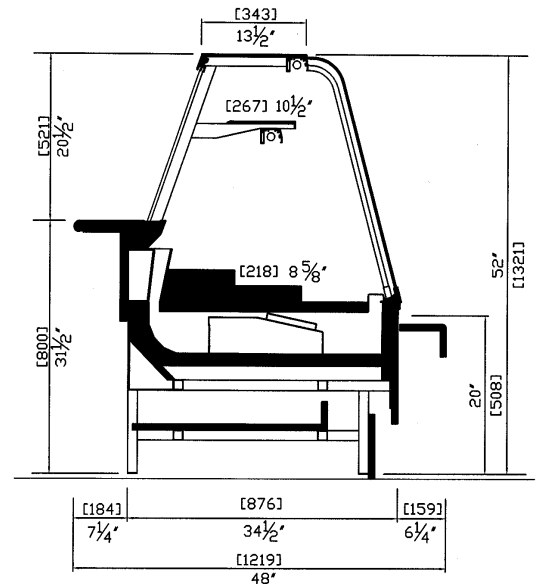

Electrical Requirements:

- 1 circuit – 115 volts – 15 amps.
- 14-2 (stranded) control line required between showcase and condensing unit.

Refrigeration Requirements:

- optional water or air cooled condensing unit
- R-22 medium/high temperature
- separate electrical line as required for condensing unit

Mechanical Requirement:

- 3" hub drain - not required if Self-Contained

Temperature:

- Internal temperature of the showcase operates between 59°F (15°C) to 63°F (17°F) at an ambient temperature of 77°F (25°C) and 50% humidity.

Specifications subject to change without notice.

Modular Series: Hot Food Showcases

Vega's Modular Series Hot Food Showcases are designed to allow for drop-in food wells, overhead heaters, or countertop hot plates. Soups, sauces, pizza and other savory products are heated, kept warm and well displayed. A stainless steel finished countertop and a cutting/work surface area are incorporated for the convenience of the staff.

Features and benefits:

- **Tilt down curved front glass**
 - streamlined design & aesthetically pleasing
 - ease of cleaning
- **Warm tone lighting above display level**
 - enhances product display & visibility
- **Electronic ballasts**
 - energy efficient & long lasting
- **Stainless steel finished platform with optional cut-out opening(s)**
 - sanitary surface
- **Plastic cutting/work surface (White)**
 - useful work space
- **Glass end panels (Mirror finish available)**
 - clear visibility
 - removable for ease of cleaning
- **Anodized finished aluminum superstructure**
 - eye pleasing & durable finish
- **Plastic laminate finished exterior**
 - matches décor
- **Melamine finished open storage shelf**
 - convenient staff storage space
- **Powder coated painted steel base frame**
 - strong & durable
- **Optional: purse shelf**
 - customer convenience & visual accent
- **Optional: Hot food wells, hot plates, heat lamps and stainless steel inserts**

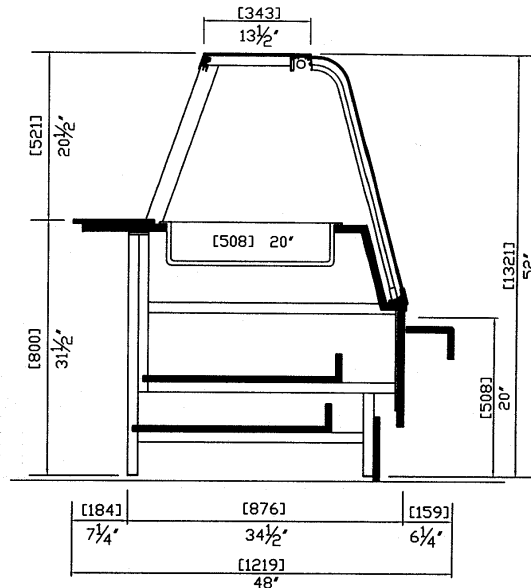

Electrical Requirements:

- 1 circuit – 115 volts – 15 amps.
- Separate electrical lines as required for hot food wells, hot plates and heat lamps.

Specifications subject to change without notice.

Modular Series: Sandwich Preparation Showcases

Vega's Modular Series Sandwich Showcases are designed to allow for an under counter refrigerated compartment with an opening for condiment inserts on top. A plastic laminate finished countertop and a cutting/work surface are incorporated for the convenience of the staff.

Features and benefits:

- **Tilt down curved front glass**
 - streamlined design & aesthetically pleasing
 - ease of cleaning
- **Warm tone lighting above display level**
 - enhances product display & visibility
- **Electronic ballasts**
 - energy efficient & long lasting
- **Plastic laminate finished platform with optional cut-out opening(s)**
 - sanitary surface
- **Plastic cutting/work surface (White)**
 - useful work space
- **Glass end panels (Mirror finish available)**
 - clear visibility
 - removable for ease of cleaning
- **Anodized finished aluminum superstructure**
 - eye pleasing & durable finish
- **Plastic laminate finished exterior**
 - matches décor
- **Powder coated painted steel base frame**
 - strong & durable
- **Optional: purse shelf**
 - customer convenience & visual accent
- **Optional: Undercounter refrigerated sandwich table**

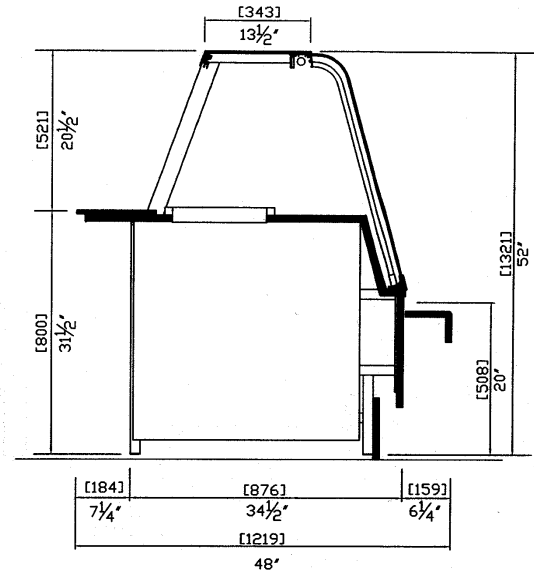

Electrical Requirements:

- 1 circuit – 115 volts – 15 amps.
- Separate electrical lines as required for refrigerated sandwich table.

Specifications subject to change without notice.

High Volume Series: Refrigerated Pastry Showcases

Vega's High Volume Series Refrigerated Pastry Showcases utilize the specially made refrigeration and airflow systems to ensure the proper environment for cakes and pastries. What sets this series apart from the Modular Series models are the additional shelf and the extra depth of each display level. Greater capacity is attained while maintaining optimal visibility.

Features and benefits:

- **Tilt down curved front glass**
 - streamlined design & aesthetically pleasing
 - ease of cleaning
- **Warm tone lighting above each display level**
 - enhances product display & visibility
- **Electronic ballasts**
 - energy efficient & long lasting
- **Three intermediate glass shelves**
 - increased capacity & visual appeal
- **Stainless steel base display platform**
 - increased capacity & sanitary surface
- **Clear acrylic sliding service doors**
 - convenient access & clear work-side view
- **Glass end panels (Mirror finish available)**
 - clear visibility
 - removable for ease of cleaning
- **Anodized finished aluminum superstructure**
 - eye pleasing & durable finish
- **Plastic laminate finished exterior**
 - matches décor
- **Melamine finished open storage shelf**
 - convenient staff storage space
- **Powder coated painted steel base frame**
 - strong & durable
- **Insulated stainless steel refrigeration pan**
 - sanitary (meets health standards)
- **Front glass defogger**
 - minimizes front glass condensation
- **Refrigeration system**
 - consistent cooling
- **Extra large refrigeration coil**
 - high humidity
- **Adjustable air circulating system**
 - maintains consistent temperature
- **Computerized temperature controller with automatic defrost**
 - active sensor reading & energy efficient
- **Optional: purse shelf**
 - customer convenience & visual accent

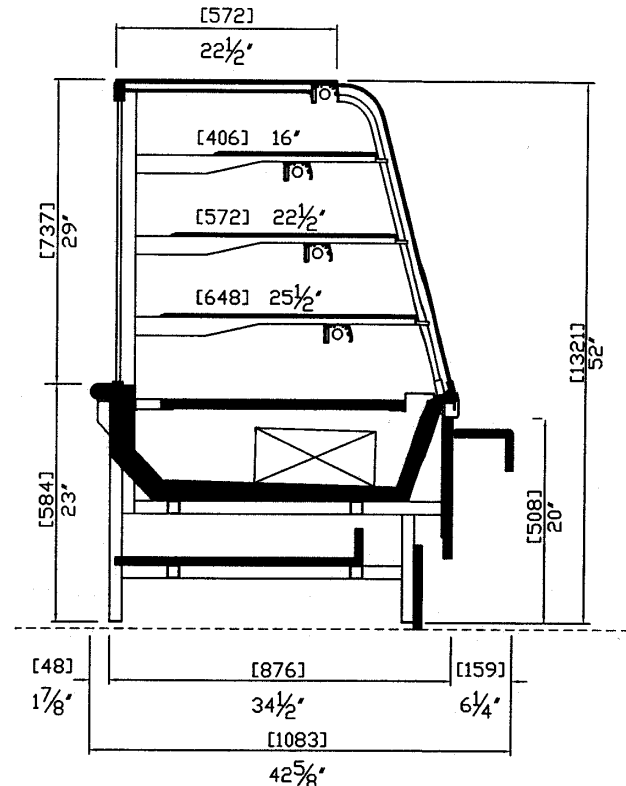

Electrical Requirements:

- 1 circuit – 115 volts –15 amp.

Refrigeration Requirements:

- optional water or air cooled condensing unit
- R-22 medium temperature
- separate electrical line as required for condensing unit

Mechanical Requirement:

- 3" hub drain – not required if Self-Contained

Temperature:

- Internal temperature of the showcase operates at 39°F (4°C) and 70% relative humidity, at an ambient temperature of 77°F (25°C) and 50% humidity.

Specifications subject to change without notice.

High Volume Series: Non-Refrigerated Bakery Showcases

Vega's High Volume Series Non-Refrigerated Bakery Showcases are designed to highlight and enhance product presentation. The combination of tilt-down curved front glass, warm tone lighting and light colored extrusions ensures the baked goods are the center of attention. What sets this series apart from the Modular Series models are the additional shelf and extra depth of each display level. Greater capacity is attained while maintaining optimal visibility.

Features and benefits:

- **Tilt down curved front glass**
 - streamlined design & aesthetically pleasing
 - ease of cleaning
- **Warm tone lighting above each display level**
 - enhances product display & visibility
- **Electronic ballasts**
 - energy efficient & long lasting
- **Three intermediate glass shelves**
 - increased capacity & visual appeal
- **Plastic laminate finished base display**
 - increased capacity & visual appeal
- **Clear acrylic sliding service doors**
 - convenient access & clear work-side view
- **Glass end panels (Mirror finish available)**
 - clear visibility
 - removable for ease of cleaning
- **Anodized finished aluminum superstructure**
 - eye pleasing & durable finish
- **Plastic laminate finished exterior**
 - matches décor
- **Melamine finished open storage shelf**
 - convenient staff storage space
- **Powder coated painted steel base frame**
 - strong & durable
- **Optional: purse shelf**
 - customer convenience & visual accent

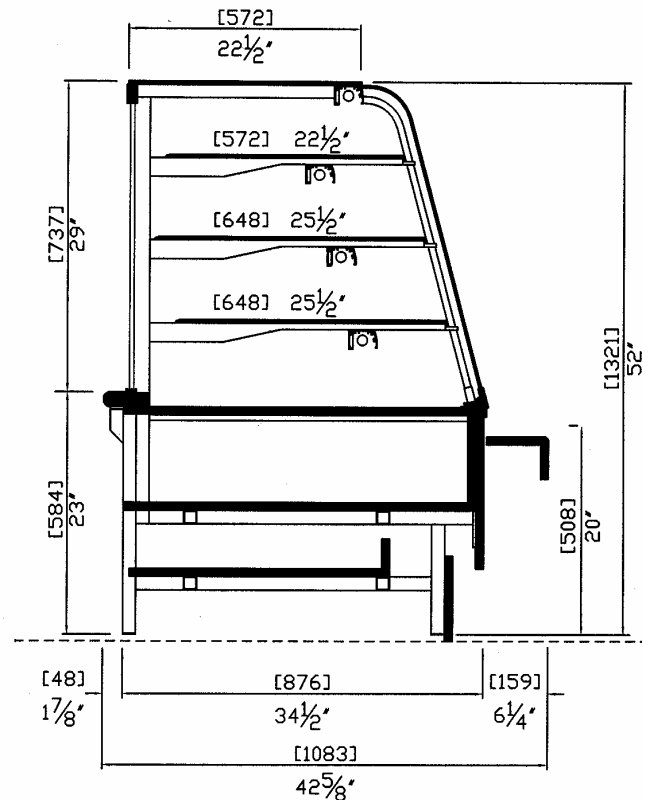

Electrical Requirements:

- 1 circuit – 115 volts – 15 amps.

Specifications subject to change without notice.

High Volume Series: Hybrid Showcases

Vega's High Volume Series Hybrid Showcases utilize the specially made refrigeration and airflow systems to ensure the proper environment for cakes and pastries. What sets this series apart from the Modular Series models are the additional shelf and the extra depth of each display level. Greater capacity is attained while maintaining optimal visibility.

Features and benefits:

- **Tilt down curved front glass**
 - streamlined design & aesthetically pleasing
 - ease of cleaning
- **Warm tone lighting above each display level**
 - enhances product display & visibility
- **Electronic ballasts**
 - energy efficient & long lasting
- **Three intermediate glass shelves**
 - increased capacity & visual appeal
- **Stainless steel base display platform**
 - increased capacity & sanitary surface
- **Clear acrylic sliding service doors**
 - convenient access & clear work-side view
- **Glass end panels (Mirror finish available)**
 - clear visibility
 - removable for ease of cleaning
- **Anodized finished aluminum superstructure**
 - eye pleasing & durable finish
- **Plastic laminate finished exterior**
 - matches décor
- **Melamine finished open storage shelf**
 - convenient staff storage space
- **Powder coated painted steel base frame**
 - strong & durable
- **Insulated stainless steel refrigeration pan**
 - sanitary (meets health standards)
- **Front glass defogger**
 - minimizes front glass condensation
- **Refrigeration system**
 - consistent cooling
- **Extra large refrigeration coil**
 - high humidity
- **Adjustable air circulating system**
 - maintains consistent temperature
- **Computerized temperature controller with automatic defrost**
 - active sensor reading & energy efficient
- **Optional: purse shelf**
 - customer convenience & visual accent

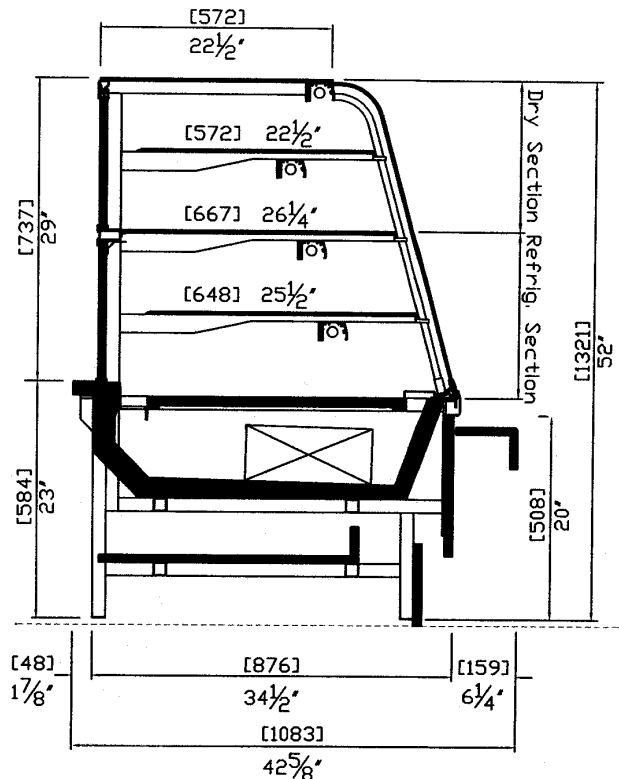

Electrical Requirements:

- 1 circuit – 115 volts – 15 amps.

Refrigeration Requirements:

- optional water or air cooled condensing unit
- R-22 medium temperature
- separate electrical line as required for condensing unit

Mechanical Requirement:

- 3" hub drain – not required if Self-Contained

Temperature:

- Internal temperature of the showcase operates at 39°F (4°C) and 70% relative humidity, at an ambient temperature of 77°F (25°C) and 50% humidity.

Specifications subject to change without notice.

"Grab n Go" Series: Refrigerated Upright Showcases

Vega's "Grab n Go" Refrigerated Upright Showcases utilize the specially made refrigeration and airflow systems to ensure the proper environment for your products. The combination of streamlined design and leading edge components enhances and maintains product appearance and freshness.

Features and benefits:

- **Warm tone lighting above each display level**
 - enhances product display & visibility
- **Electronic ballasts**
 - energy efficient & long lasting
- **Two intermediate glass shelves**
 - increased capacity & visual appeal
- **Two step stainless steel display platform**
 - increased capacity & visual
- **End panels (Mirror finish available)**
 - increased capacity & visual
- **Anodized finished aluminum superstructure**
 - eye pleasing & durable finish
- **Plastic laminate finished exterior**
 - matches décor
- **Powder coated painted steel base frame**
 - strong & durable
- **Insulated stainless steel refrigeration pan**
 - sanitary (meets health standards)
- **Refrigeration system**
 - consistent cooling
- **Extra large refrigeration coil**
 - high humidity
- **Adjustable air circulating system**
 - maintains consistent temperature
- **Computerized temperature controller with automatic defrost**
 - active sensor reading & energy efficient

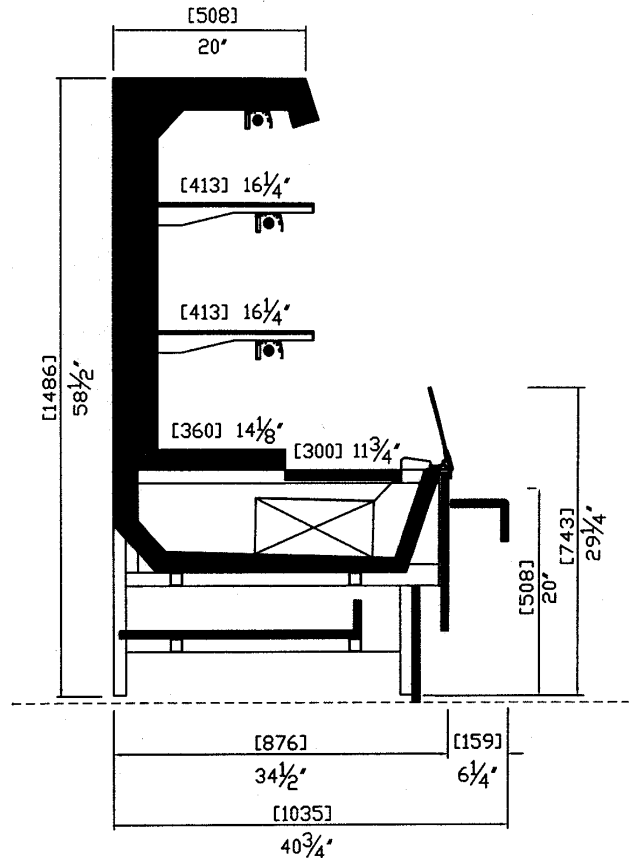

Electrical Requirements:

- 1 circuit – 115 volts – 15 amps.

Refrigeration Requirements:

- optional water or air cooled condensing unit
- R-22 medium temperature
- separate electrical line as required for condensing unit

Mechanical Requirement:

- 3" hub drain – not required if Self-Contained

Temperature:

- Internal temperature of the showcase operates at 39°F (4°C) at an ambient temperature 77°F (25°C) and 50% humidity.

Specifications subject to change without notice

"Grab n Go" Series: Refrigerated / Non Refrigerated Combo Showcases

Vega's "Grab n Go" Series Refrigerated / Non Refrigerated Showcases utilize the specially made refrigeration and airflow systems to ensure the proper environment for your products. The combination of streamlined design and leading edge components enhances and maintains product appearance and freshness.

Features and benefits:

- **Curved front glass**
 - streamlined design & aesthetically pleasing
 - ease of cleaning
- **Warm tone lighting above each display level**
 - enhances product display & visibility
- **Electronic ballasts**
 - energy efficient & long lasting
- **One intermediate glass shelf**
 - increased capacity & visual appeal
- **Two step stainless steel display platform**
 - increased capacity & visual
- **Clear acrylic sliding service doors**
 - convenient access & clear work-side view
- **End panels (Mirror finish available)**
- **Anodized finished aluminum superstructure**
 - eye pleasing & durable finish
- **Plastic laminate finished exterior**
 - matches décor
- **Powder coated painted steel base frame**
 - strong & durable
- **Insulated stainless steel refrigeration pan**
 - sanitary (meets health standards)
- **Refrigeration system**
 - consistent cooling
- **Extra large refrigeration coil**
 - high humidity
- **Adjustable air circulating system**
 - maintains consistent temperature
- **Computerized temperature controller with automatic defrost**
 - active sensor reading & energy efficient

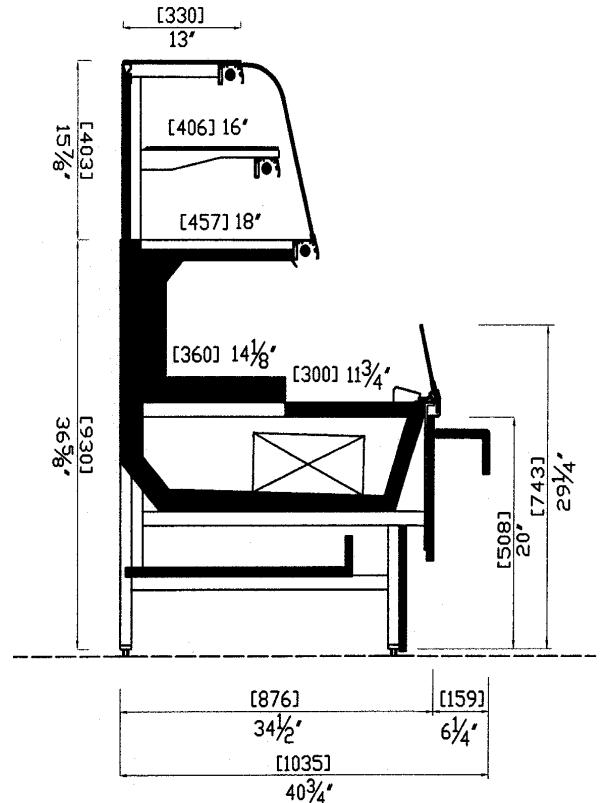

Electrical Requirements:

- 1 circuit – 115 volts – 15 amps.

Refrigeration Requirements:

- optional water or air cooled condensing unit
- R-22 medium temperature
- separate electrical line as required for condensing unit

Mechanical Requirement:

- 3" hub drain – not required if Self-Contained

Temperature:

- Internal temperature of the showcase operates at 39°F (4°C) at an ambient temperature 77°F (25°C) and 50% humidity.

Specifications subject to change without notice

"Grab n Go" Series: Refrigerated Lowboy Showcase

Vega's "Grab n Go" Series Refrigerated Lowboy Showcases utilize the specially made refrigeration and airflow systems to ensure the proper environment for meats and cheeses. The combination of streamlined design and leading edge components enhances and maintains product appearance and freshness.

Features and benefits:

- **Warm tone lighting above each display level**
 - enhances product display & visibility
- **Electronic ballasts**
 - energy efficient & long lasting
- **Two step stainless steel display platform**
 - increased capacity & visual
- **Plastic laminate finished work shelf**
 - useful work space
- **Plastic laminate finished exterior**
 - matches décor
- **Powder coated painted steel base frame**
 - strong & durable
- **Insulated stainless steel refrigeration pan**
 - sanitary (meets health standards)
- **Refrigeration system**
 - consistent cooling
- **Extra large refrigeration coil**
 - high humidity
- **Adjustable air circulating system**
 - maintains consistent temperature
- **Computerized temperature controller with automatic defrost**
 - active sensor reading & energy efficient
- **Optional: purse shelf**
 - customer convenience & visual accent

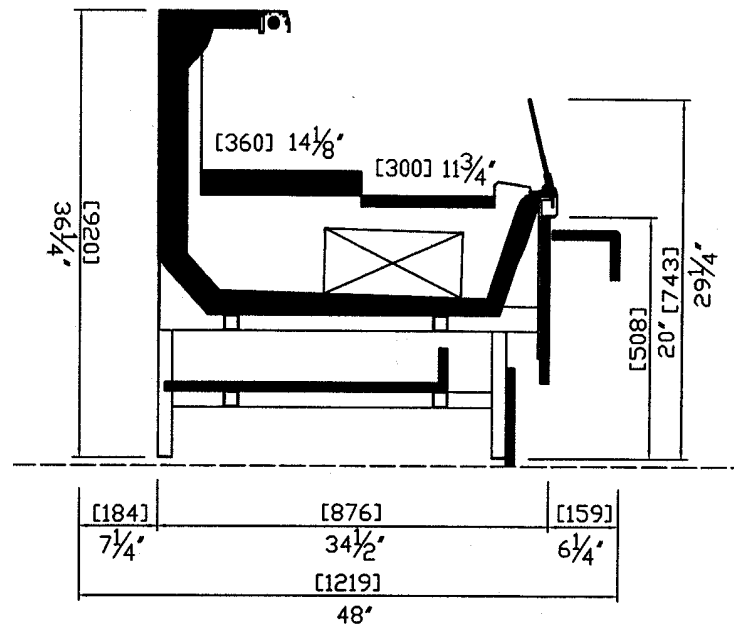

Electrical Requirements:

- 1 circuit – 115 volts – 15 amps.

Refrigeration Requirements:

- optional water or air cooled condensing unit
- R-22 medium temperature
- separate electrical line as required for condensing unit

Mechanical Requirement:

- 3" hub drain – not required if Self- Contained

Temperature:

- Internal temperature of the showcase operates at 39°F (4°C) and 70% at an ambient temperature of 77°F (25°C) and 50% humidity.

Specifications subject to change without notice.

Café Series: Refrigerated Showcases

Vega's Café Series Refrigerated Showcases are extensions of the Modular Series displays with the addition of the unique display platforms and convenient front tray shelf for the customers. The computerized refrigeration and airflow systems are designed to ensure the proper environment for all types of products.

Features and benefits:

- **Tilt down curved front glass**
 - streamlined design & aesthetically pleasing
 - ease of cleaning
- **Warm tone lighting above each display level**
 - enhances product display & visibility
- **Electronic ballasts**
 - energy efficient & long lasting
- **One intermediate glass shelf**
 - increased capacity & visual appeal
- **Intermediate top-glass barrier**
 - reduces condensation on top of showcase
- **Two step stainless steel display platform**
 - increased capacity & visual appeal
- **Clear acrylic sliding service doors**
 - convenient access & clear work-side view
- **Plastic laminate finished work shelf**
 - useful work space
- **Glass end panels (Mirror finish available)**
 - clear visibility
 - removable for ease of cleaning
- **Anodized finished aluminum superstructure**
 - eye pleasing & durable finish
- **Plastic laminate finished exterior**
 - matches décor
- **Plastic laminate finished tray shelf**
 - customer convenience & visual accent
- **Melamine finished open storage shelf**
 - convenient staff storage space
- **Powder coated painted steel base frame**
 - strong & durable
- **Insulated stainless steel refrigeration pan**
 - sanitary (meets health standards)
- **Front glass defogger**
 - minimizes front glass condensation
- **Refrigeration system**
 - consistent cooling
- **Extra large refrigeration coil**
 - high humidity
- **Adjustable air circulating system**
 - maintains consistent temperature
- **Computerized temperature controller with automatic defrost**
 - active sensor reading & energy efficient

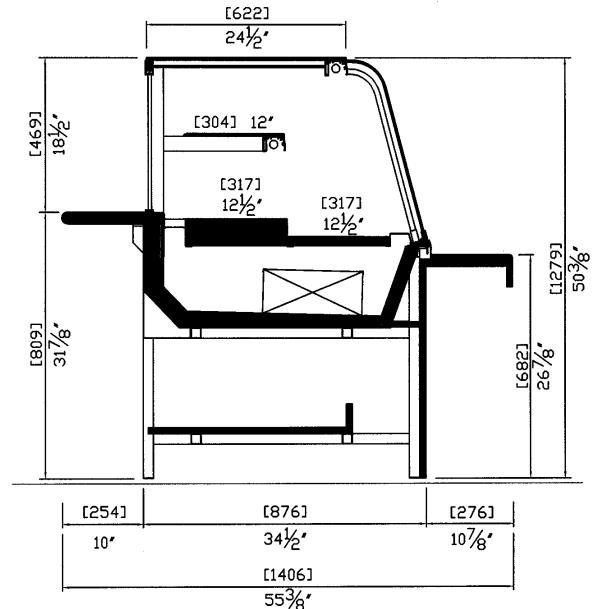

Electrical Requirements:

- 1 circuit – 115 volts – 15 amps.

Refrigeration Requirements:

- optional water or air cooled condensing unit
- R-22 medium temperature
- separate electrical line as required for condensing unit

Mechanical Requirement:

- 3" hub drain – not required if Self-Contained

Temperature:

- Internal temperature of the showcase operates at 39°F (4°C) and 70% relative humidity, at an ambient temperature of 77°F (25°C) and 50% humidity.

Specifications subject to change without notice.

Café Series: Non-Refrigerated Showcases

Vega's Café Series Non-Refrigerated Showcases are extensions of the Modular Series displays with the addition of the unique display platforms and convenient front tray shelf for the customers. This series retains the tilt-down curved front glass, warm tone lighting and light colored extrusions to ensure optimal visibility.

Features and benefits:

- **Tilt down curved front glass**
 - streamlined design & aesthetically pleasing
 - ease of cleaning
- **Warm tone lighting above each display level**
 - enhances product display & visibility
- **Electronic ballasts**
 - energy efficient & long lasting
- **One intermediate glass shelf**
 - increased capacity & visual appeal
- **Two step stainless steel display platform**
 - increased capacity & visual appeal
- **Clear acrylic sliding service doors**
 - convenient access & clear work-side view
- **Plastic laminate finished work shelf**
 - useful work space
- **Glass end panels (Mirror finish available)**
 - clear visibility
 - removable for ease of cleaning
- **Anodized finished aluminum superstructure**
 - eye pleasing & durable finish
- **Plastic laminate finished exterior**
 - matches décor
- **Plastic laminate finished tray shelf**
 - customer convenience & visual accent
- **Melamine finished open storage shelf**
 - convenient staff storage space
- **Powder coated painted steel base frame**
 - strong & durable

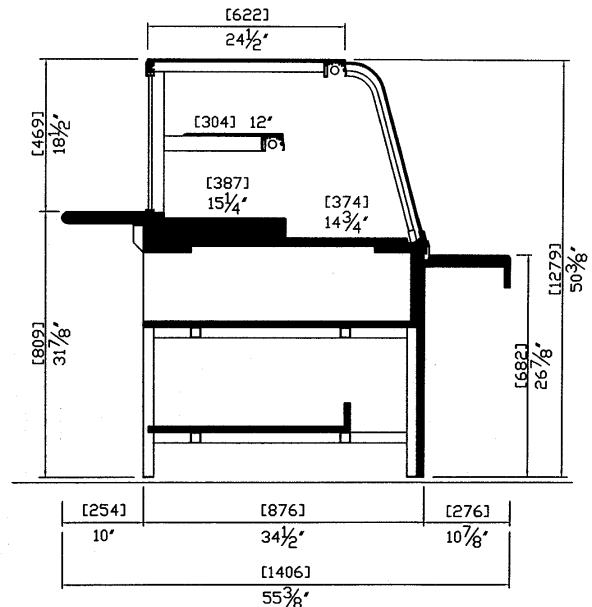

Electrical Requirements:

- 1 circuit – 115 volts – 15 amps.

Specifications subject to change without notice.

Café Series: Hot Food Showcases

Vega's Café Series Hot Food Showcases are designed to allow for drop-in food wells, overhead heaters, or countertop hot plates. Soups, sauces, pizza and other savory products are heated, kept warm and well displayed. A stainless steel finished countertop and a cutting/work surface are incorporated for the convenience of the staff, while the front tray shelf is provided to the customers.

Features and benefits:

- **Tilt down curved front glass**
 - streamlined design & aesthetically pleasing
 - ease of cleaning
- **Warm tone lighting above display level**
 - enhances product display & visibility
- **Electronic ballasts**
 - energy efficient & long lasting
- **Stainless steel finished platform with optional cut-out opening(s)**
 - sanitary surface
- **Plastic cutting/work surface (White)**
 - useful work space
- **Glass end panels (Mirror finish available)**
 - clear visibility
 - removable for ease of cleaning
- **Anodized finished aluminum superstructure**
 - eye pleasing & durable finish
- **Plastic laminate finished exterior**
 - matches décor
- **Plastic laminate finished tray shelf**
 - customer convenience & visual accent
- **Melamine finished open storage shelf**
 - convenient staff storage space
- **Powder coated painted steel base frame**
 - strong & durable
- **Optional: Hot food wells, hot plates, heat lamps and stainless steel inserts**

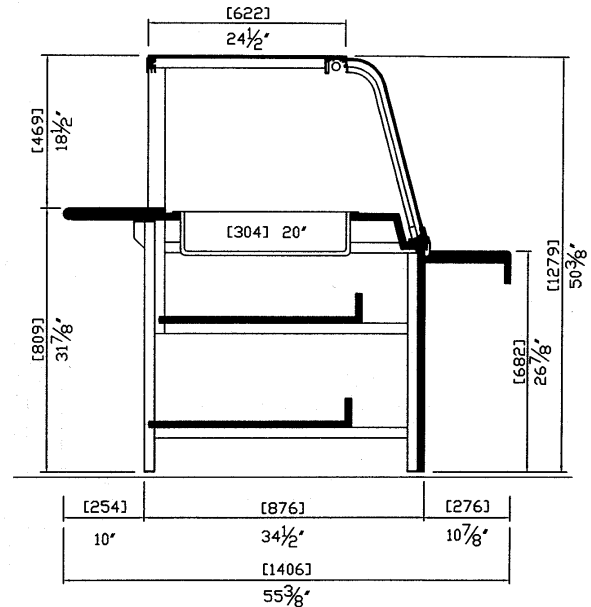

Electrical Requirements:

- 1 circuit – 115 volts – 15 amps.
- Separate electrical lines as required for hot food wells, hot plates and heat lamps.

Specifications subject to change without notice.

Café Series: Sandwich Preparation Showcases

Vega's Café Series Sandwich Showcases are designed to allow for an under counter refrigerated compartment with an opening for condiment inserts on top. A plastic laminate finished countertop and a cutting/work surface are incorporated for the convenience of the staff, while the front tray shelf is provided to the customers.

Features and benefits:

- **Tilt down curved front glass**
 - streamlined design & aesthetically pleasing
 - ease of cleaning
- **Warm tone lighting above display level**
 - enhances product display & visibility
- **Electronic ballasts**
 - energy efficient & long lasting
- **Plastic laminate finished platform with optional cut-out opening(s)**
 - sanitary surface
- **Plastic cutting/work surface (White)**
 - useful work space
- **Glass end panels (Mirror finish available)**
 - clear visibility
 - removable for ease of cleaning
- **Anodized finished aluminum superstructure**
 - eye pleasing & durable finish
- **Plastic laminate finished exterior**
 - matches décor
- **Plastic laminate finished tray shelf**
 - customer convenience & visual accent
- **Powder coated painted steel base frame**
 - strong & durable
- **Optional: Undercounter refrigerated sandwich table**

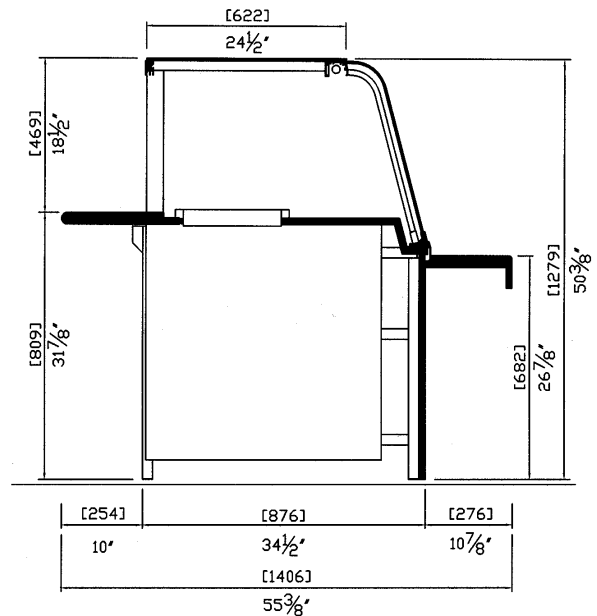

Electrical Requirements:

- 1 circuit – 115 volts – 15 amps.
- Separate electrical lines as required for refrigerated sandwich table.

Specifications subject to change without notice.

Custom Front Service Counter

Vega produces a wide variety of Custom Front Service Counters to complete the overall display design. Any particular dimensions, angles and finishes are made to order and seamlessly integrated with the showcases.

Features and Benefits

- **Plastic laminate finished countertop**
 - useful work surface (i.e. cash counter)
 - matches décor
- **Plastic laminate finished front exterior**
 - matches décor
- **Melamine finished open storage shelf**
 - convenient worker storage space
- **Powder coated painted steel base frame**
 - strong & durable
- **Optional: purse shelf**
 - customer convenience & visual accent

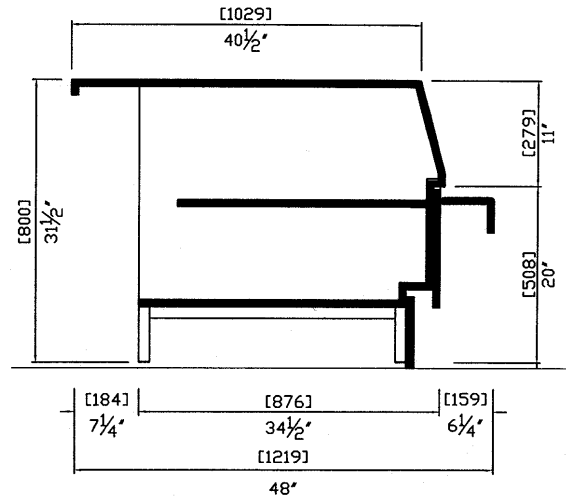

Specifications subject to change without notice.

Options and Accessories

Vega is the leader in customized merchandising displays. We provide a full complement of optional extras and accessories with a wide range of colors and finishes. If there are any other items required, we can accommodate them upon request.

Items, Features, and Benefits

Corner Showcases

- refrigerated or non-refrigerated
 - to meet required showcase layout
- with or without glass superstructure
 - for display or for service
- custom angles (inside or outside)
 - to meet required layout

Anodized Aluminum Cake Trays

- champagne color
- black
- silver
- custom sizes

Front Glass

- straight front glass
 - streamlined design & aesthetically pleasing
- for ease of cleaning

Glass Shelves

- additional glass shelves with/without lights
 - for added display space

Pull-out Drawer

- for non-refrigerated showcases
 - ergonomic & convenient access to product

Purse Shelf

- clear lacquer finished oak, solid maple or matching laminate purse shelf
 - customer convenience & visual accent
- fluorescent lights (under)
 - for visual accent
- rubber bumper guard (front)
 - for protection

Electric / Hot Gas Condensate Pan

- when floor drain is not available

Sump Pump

- when floor drain is not available

Condiment Holder

- located along packaging shelf

Utensil Holder/Well

- located along packaging shelf
 - for convenient worker use

Storage Compartments

- to fit bags and boxes
 - for convenient worker use

Specifications subject to change without notice.

Wall Mounted / Backwall Display System

Vega provides a wide range of backwall display systems and merchandisers incorporating adjustable shelving, canopies and cabinets. Custom sizes are available upon request.

Items and Features

Self Standing Shelving System

- Standard 1220 mm / 4'-0" (width) sections
- Powder coated paint finished steel backwall standards (Almond color)
- Optional backwall panels
 - unfinished, ready for wall covering,
 - plastic laminate finished or ready for tiles
- Custom dimensions available

Shelves

- Standard 1220 mm / 4'-0" (length)
- Adjustable angles – horizontal, 15° & 30°
- Maple dowel bread shelves
 - 457 mm / 18" (depth)
- Plywood shelves
 - maple, oak or plastic laminate finished
 - 413 mm / 16 1/4" (depth)
- Glass shelves (horizontal only)
 - 254 mm / 10" (depth)
- Anodized aluminum dowel bread shelves
 - champagne color
 - with or without lights

Storage Cabinets

- Standard 1220 mm / 4'-0" (length) sections
- Standard 572 mm / 22 1/2" (depth)
- Plastic laminate finished countertop
- Optional doors
 - plastic laminate or clear lacquer finished oak or maple
- Melamine finished internal shelf (Almond color)
- Custom dimensions available

Angled Mirror Above Shelving

- Custom dimensions available

Wall Mounted Shelving System

- Standard 1220 mm / 4'-0" (width) sections
- Powder coated paint finished steel wall standards (Almond color)
- Custom dimensions available

Light Canopy Above Backwall

- Standard 610 mm / 2'-0" (depth)
- Standard 305 mm / 1'-0" (height)
- Lights
 - with or without
 - fluorescent or flood lights
- Fascia
 - unfinished, ready for wall covering, plastic laminate finished or oak plywood finished
 - with or without wood trim
- Custom dimensions available

Drop Ceiling Above Showcase

- Standard 1220 mm / 4'-0" (depth)
- Standard 305 mm / 1'-0" (height)
- Lights
 - with or without
 - flood or pendant light
- Fascia
 - unfinished, ready for wall covering, plastic laminate finished, oak or maple plywood finished
- Custom dimensions available

- ***Specifications are subject to change without notice.***

Wall Mounted / Backwall Display System

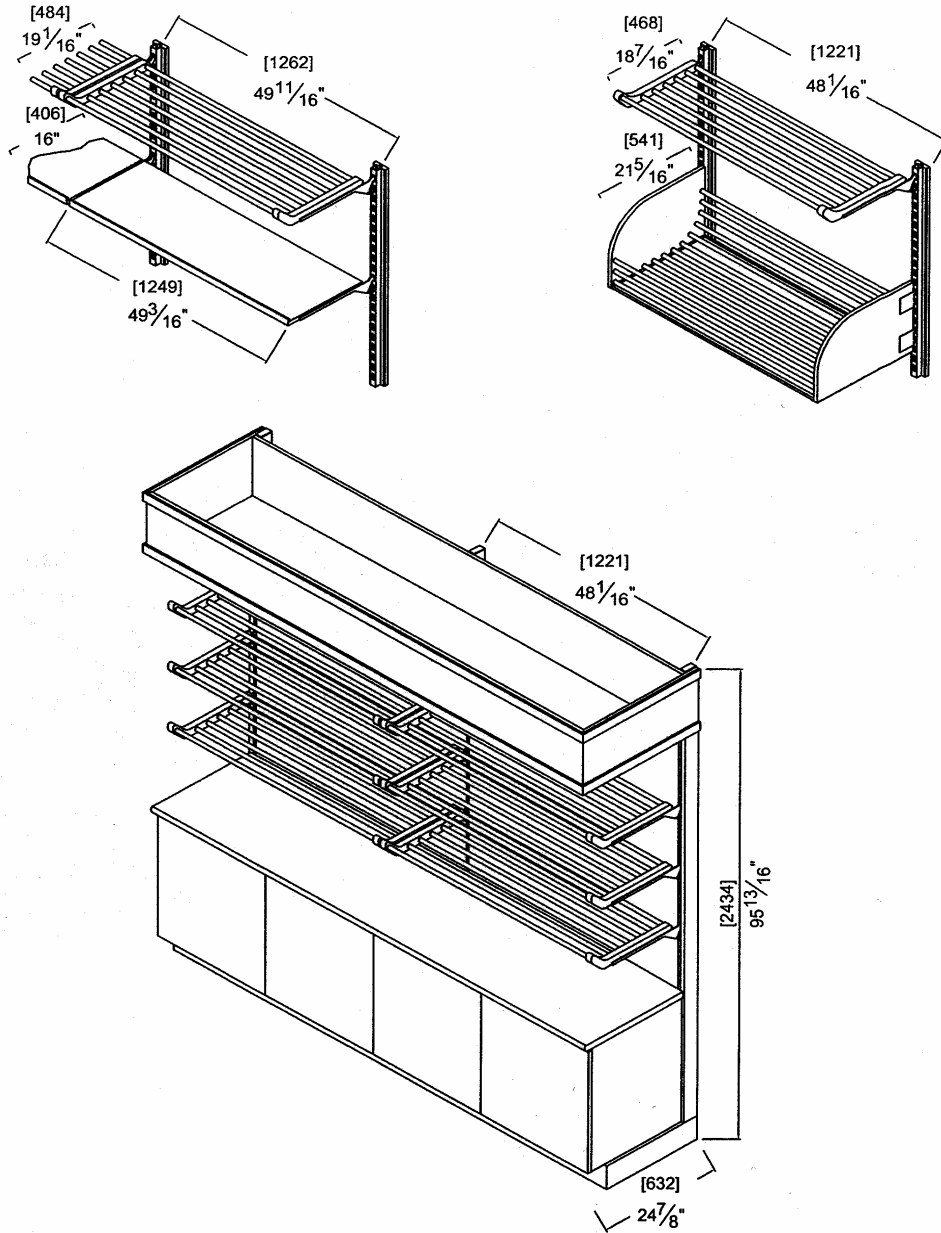

Projects/Installations
- Canada -

BRITISH COLUMBIA

Afterthoughts Restaurant
Abbotsford

B.C. Institute of Technology
Inglis Building, Burnaby
Town Square, Burnaby

Café Ami
Various locations -
Vancouver

Calhoun's Bakery Café
Vancouver

**Canadian Maple Delights
Gourmet Bistro & Shoppe**
Vancouver

Dynamic Chocolates
(Bottacelli's), Delta

The Delly
S.U.B. – University of BC
Vancouver

Fratelli's Bakery
Vancouver

Platinum Gym
Surrey

**House of Brussels
Chocolates**
Vancouver

Java Hut
Chilliwack
Chilliwack Civic Centre
Langley
Surrey
Vancouver

Kits Coffee Company
Vancouver

La Grotta Del Formaggio
Vancouver

La Mascotte Bakery & Café
Vancouver

La Petit France
Vancouver

Les Amis Du Frommage
Vancouver

McDonald's - McCafé
Langley
UBC
Walnut Grove

McDonald's Restaurants
Various locations –
Vancouver
Vancouver Island
BC Interior

Murchie's Tea & Coffee
Richmond
West Vancouver

Pacific Culinary Institute
Vancouver

Patisserie Lebeau
Vancouver

Patisserie Bordeaux
Vancouver

Portofino Fine Breads
Victoria

Pure Vanilla Bakery
Victoria

Sidney Bakery
Sidney

Tony's Coffee
Vancouver

Trekkers Restaurant
University of BC
Vancouver

Uprising Breads
Vancouver

Viva Restaurant
Vancouver

PRAIRIES

Calgary Co-Op
Calgary, Alberta

Cologne Bakery
Calgary, Alberta

McDonald's Restaurants
Various locations, Alberta
Edmonton, Alberta

St. Mary Pastry
Edmonton, Alberta

Obsessions
Kananaskis, Alberta

McDonald's Restaurants
Various locations,
Saskatchewan

Gypsy Bakery
Churchill, Manitoba

McDonald's Restaurants
Various locations, Manitoba

ONTARIO

A&P Stores
Ontario

Alcoa Bakery
Toronto

**Angelo's Italian Bakery &
Deli**
London

The Barn Fruit Market
Various locations

Beck's Bakery
Pembroke

Cappuccino Bakery
Maple

Dimpflmeier
Toronto

Europa Bakery
Toronto

La Rea Bakery
Weston

Lakeside Bakery
Leamington

Lisboa Bakery
Toronto

Loblaws Stores
Ontario

**Maplegate Italian Bakery
& Delicatessen**
Maple

Mr. Cappuccino Café
Niagara Falls

St. Phillips Bakery
Vaughan
Woodbridge

Sigrid's Café
Barrie

Vincenzo's
Kitchener

QUEBEC

Canadian Maple Delights
Montreal

ATLANTIC

Real Atlantic Superstore
Atlantic Canada

Projects/Installations
- USA -

USA – Arkansas

Java Roasting
Little Rock

USA – California

A Sweet Affair Bakery
Walnut Creek

Chocolatt
West Los Angeles

Eppler's Bakery
San Francisco

Gina's Pizza and Pasta
Laguna Beach

Goldilock's Bakery
Sacramento

**La Boulangerie French
Bakery & Café**
Fresno

Lorraine Boulangerie
South Lake Tahoe

Lovebirds
Alhambra
Pasadena
Monterey Park

Plantation Station
San Diego

**Tahoe House
Restaurant & Bakerei**
Tahoe City

Walnut Creek Baking Co.
Walnut Creek

USA – Colorado

Belvedere Chocolates
Greenwood Village
Denver
Castlerock

USA - Delaware

**Homegrown Café
& Gourmet To Go**
Newark

USA – Florida

Delices De France
Miami

Romanicos
Miami

USA – Georgia

Sweet Temptations
Suwanee

USA – Hawaii

Honolulu Coffee Company
Honolulu

USA – Idaho

Thomas Hammer Coffee
Boise

USA – Illinois

Deerfield Bakery
Buffalo Grove

Lotus Garden
Deerfield

USA – Indiana

Café go Lightly
Evansville

USA – Louisiana

Coffee Bean
Baton Rouge

USA - Maryland

Casa Blanca Bakery
Langley Park

USA – Massachusetts

Cerrato's Pastry Shop
Springfield

D'Amici's Bakery
Lynn

George's Bakery
Worester

Jim's Bagel and Bake Shoppe
Gloucester

Sweet Creations
Salem

Sweet Spot Bakery
Melrose
Woburn

USA - Michigan

Chocolate Heaven
Shelby Township

USA - New Hampshire

Swan Chocolates
Merrimack

USA – New Jersey

Bella Palermo
Elizabeth

MagicBrain CyberCafé
Cape May

USA – New York

A Taste of Home
North Bellmore

USA – Nevada

Jitters / Espresso Yourself
Henderson

Las Vegas Hilton
Andiamo Restaurant
Las Vegas

Las Vegas Hilton
Coffee Bar
Las Vegas

USA - North Carolina

Jimmy's Java
Boone

USA – Oregon

Moonstruck Chocolatier
Portland

BJ'S Coffee
Forest Grove

USA – Tennessee

Provence Bakery
Nashville

USA - Texas

The Upper Crust Bakery
Austin

USA – Virginia

Our Daily Bread
Blacksburg

Sentara Careplex Hospital
Hampton

USA – Washington

Alki Bakery
Seattle

Bacco Café
Pike Place Market

CJ's Bakery
Black Diamond

Holly's Espresso
Seattle

Le Panier
Seattle

Michou
Seattle

The Mill Bakery
Kent

Thomas Hammer Coffee
Spokane

Village Bakery
Bellingham

Zoka Coffee Roasters
Seattle

USA - Wisconsin

Johnston Bakery
Sheboygan

Projects/Installations

- CARIBBEAN –

Aruba

A Taste of Belgium

Puerto Rico

Don Pepin Factory Shop
Bayamon

Caribbean Cinemas
Various locations

- BERMUDA -

Fairmont Hamilton Princess

- JAPAN -

Macchinesti Coffee
Minato-ku, Tokyo
Sumida-ku, Tokyo

- MEXICO -

Flamingos
Mexico

Pasteleria El Molino
Mexico City

Villa del Palmar
Nuevo Vallarta

- SWEDEN -

GA Handelsbolag
Stockholm

Projects/Installations

